

CS200

Coalsizer

For Shearer EL3000 and AFC

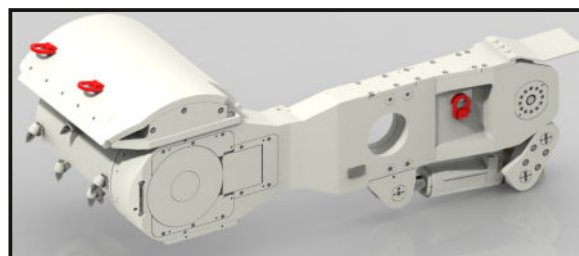

Application

For maximum productivity in high seams or difficult mining conditions, HBT shearers and face conveyors can be equipped with an optional coalsizer.

Main function of the coalsizer is to reduce the size of coal to fit through the tunnel between shearer mainframe and AFC. It crushes large lumps of coal to a predetermined size before they are fed under the tunnel section of the shearer main frame by the flights of the armored face conveyor. This ensures continuous and trouble-free transportation of the extracted coal.

The coalsizer can be mounted on the shearer's mainframe or on an adapter line pan on the face conveyor.

On the shearer, the coalsizer is pivot mounted to the mainframe. A gearbox is attached to the face side of the shell with the electric motor inserted from the goaf side of the shell. The shell also acts as a bearing location for the cutting drum.

On the conveyor, the coalsizer is mechanically attached to the main frame with an adaptor line pan, either on the left or right on the goaf side of the main frame. Active lifting in the vertical direction (e.g. AFC rear drive) is possible.

The coalsizer can be ordered separately for installation during rebuild or overhaul.

Major Units

- Coalsizer arm
- Single speed AFC motor
- Gearbox
- Cutting drum
- Lifting arrangement

Technical Specification

Gearbox Rating	200 kW
Gear Reduction Ratio	7.29
Input Speed RPM	1470/50 Hz (1760/60 Hz)
Output Drum Speed	200 RPM (240 @ 60 Hz)
Lubrication Oil	HBT standard gearbox oils, viscosity class 320 or 460 1.6 - 2.0 liters
Full Load Bulk Oil Temp.	75 – 85 °C
Internal Cooling Water Flow (Gearbox + Motor)	25 l/min
Max. Cooling Water Pressure (Gearbox + Motor)	35 bar
Max. Allowable Gear Case Temp.	100 °C
Lifting Cylinder Valve Setting	250 bar
Drum Diameter	900 mm (2 ft 11.4 in.)
Max. Drum Web	740 mm

Standard Features

- Transmission Rating of 200 kW suits HBT SM200M (200 kW motor)
- Quill shaft transmission protection
- Non handed unit (can fit either end of machine)
- Integral water cooling for transmission and motor
- Square drum hub drive for drum
- Complete with unique HBT anti-shock lift mechanism
- Height adjustment mechanism (hydraulic control unit).

CS200 Coalsizer

Dimensions - View #1

All dimensions are approximate

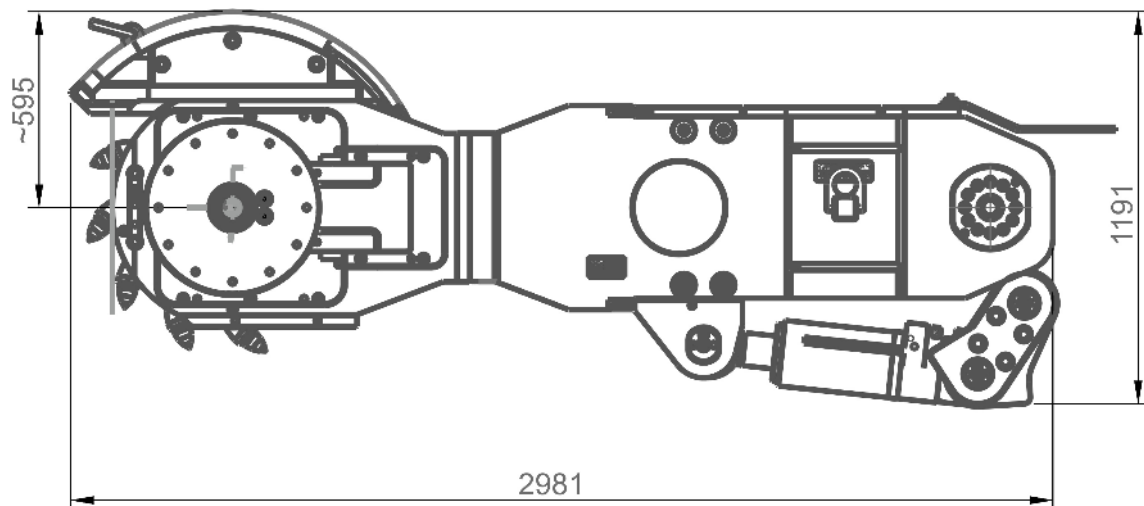

Dimensions - View #2

All dimensions are approximate

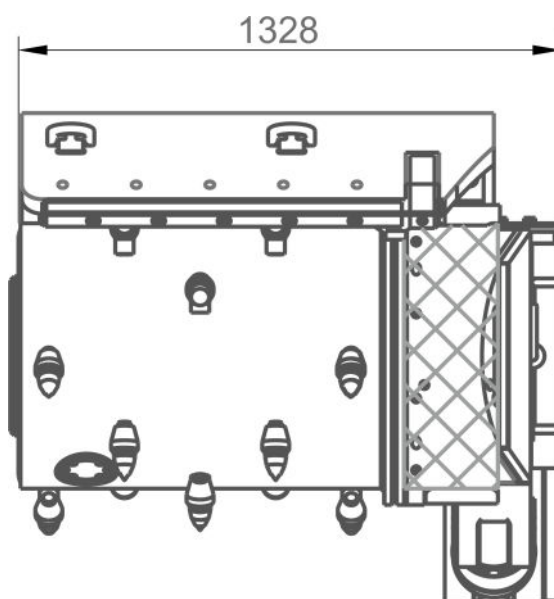

CS200 Coalsizer

Dimensions - View #3

All dimensions are approximate

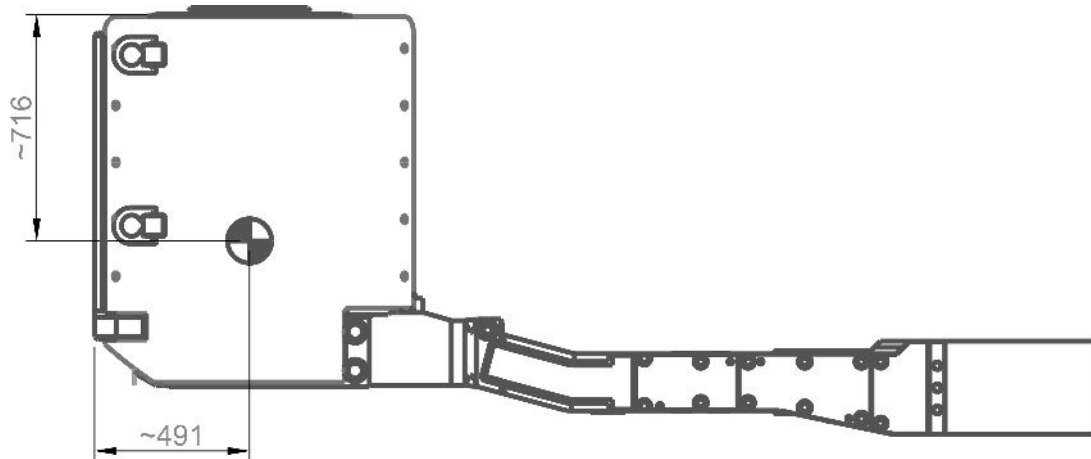

Examples of Realization

CS200 on EL3000 Shearer

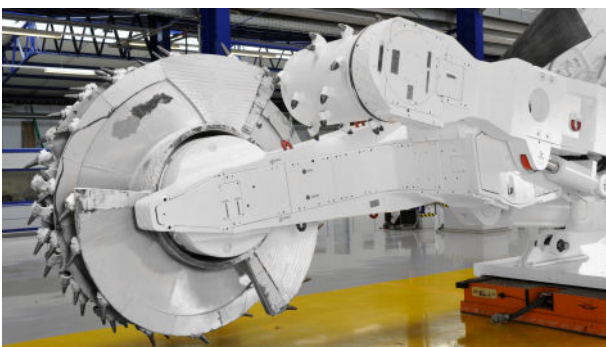

CS200 on Armored Face Conveyor

