

PMC-D/PMC-D20

Drive Control Unit

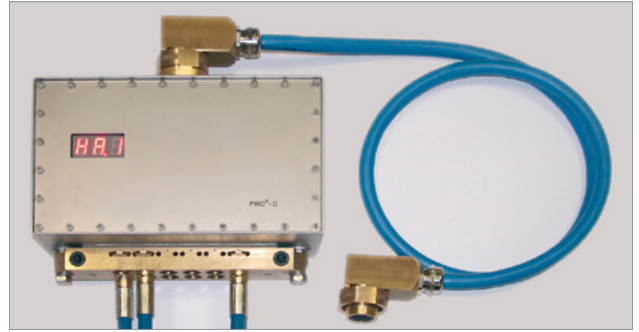

The intrinsically safe HBT PMC-D control is used on shearer or plow faces to provide high level AFC (armed face conveyor) and plow automation. Each Drive unit needs to be equipped with one PMC-D control unit and equivalent I/O to operate the CST drives or UEL gearbox functions.

In such a system a HBT PMC-V provides the Human Machine Interface (HMI) to interfere with the PMC-D controls to operate manual mode, visualize and change parameters and show actual process values. Within a PMC-D system minimum one and typically up to 3 PMC-Vs are in equal operation.

The PMC-D system can control extremely sensitive the speed and torque of highly powered AFC CST drive. Using Profibus network all PMC-Ds and PMC-Vs in a system could exchange process data over long distances with high frequency.

Attributes of PMC-D/PMC-D20 Control Unit:

- > Robust stainless steel design
- > Highly reliable OS37 plug technology for complete gear box control
- > SKK24 hose cables for bus system and additional I/O connection
- > IP 68 rating (48 hr @ 1 m [3.28 ft] under water)
- > HMI with 24 multi feedback keys (pressure point, led light)
- > 63.5 mm (2.5 in) graphical monochrome display
- > Multi language support
- > Maintainability (brass bar mounting)
- > Optional eight (8) additional ports for acceleration sensors (PMC-D20)

Exemplarily System Layout of a PMC-D System (Shearer Face)

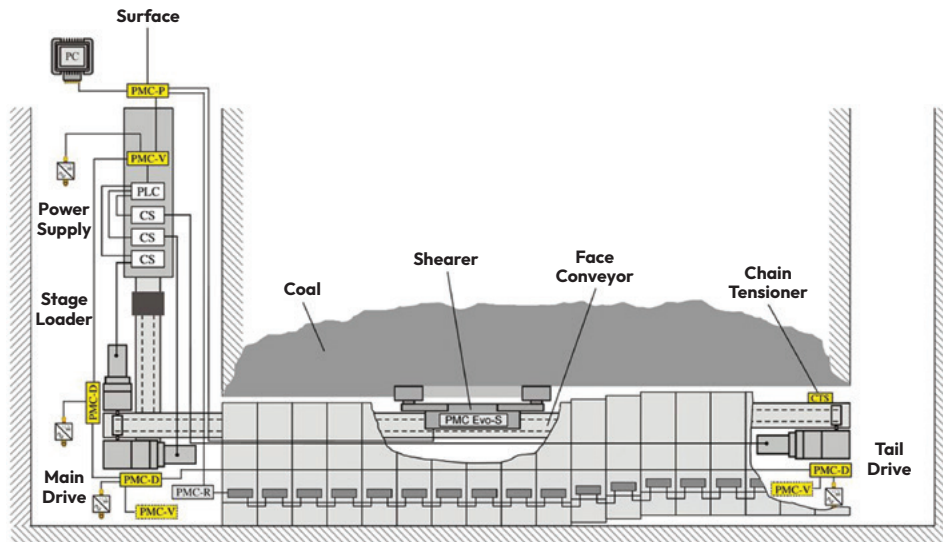

PMC-D/PMC-D20 Drive Control Unit

FEATURES

Main Features PMC-D Drive Control System

- > “Distributed controller Intelligence per drive”
- > Synchronized heavy load start up
- > Soft start up
- > Load sharing between conveyor drives
- > Overload protection
- > Motor braking feature
- > Further used in plow operations:
 - > Precise position detection
 - > Overload protection

Additional Features

- > Usage of PMC-D for chain tensioning of AFC (front and rear conveyor) and Beam Stage Loader (BSL)
- > In conjunction with Slacktronik direct BSL chain slack control and relating chain tensioning
- > Usage of PMC-D for high accurate plow position control and monitoring
- > Support VFD controlled drive applications
- > Optional integration of vibration analysis function with PMC-D20 control unit:
 - > Acceleration sensor interface for 8 sensor
 - > Integrated communication for vibration analysis

Electrical Data

Parameter	Typical Value	Maximum Ratings
Supply Voltage	12V DC	9.5 V – 13.2 V
Supply Current	1 A	1.5 A

Environmental Data

Parameter	Symbol	Typical Value	Maximum Ratings
Temperature	T _{amb}	20° C (68° F)	-20° C – +40° C (-4° F – +104° F)

Global Certifications

- > Europe: ATEX
- > U.S.: MSHA
- > Russia: GOST
- > Australia: IECEX, ANZEx
- > China: MA
- > More certifications on demand

Via a decentralized visualization and control unit at the face and/or the surface, HBT condition monitoring and data visualization capabilities are supported.

Vibration Analysis

- > Vibration Analysis (former VibraGuard) provides vibration monitoring functionality for longterm health monitoring of the following longwall related equipment:
 - > CST gearbox and relating motor
 - > UEL gearbox and relating motor
 - > Stage loader gearbox and relating motor
 - > Crusher and relating motor
 - > Shearer haulage and ranging arm gearboxes
 - > Water/HFA pump station

PMC-D/PMC-D20 Drive Control Unit

PMC-D Dimensions and Plug Assignments

All dimensions are approximate.

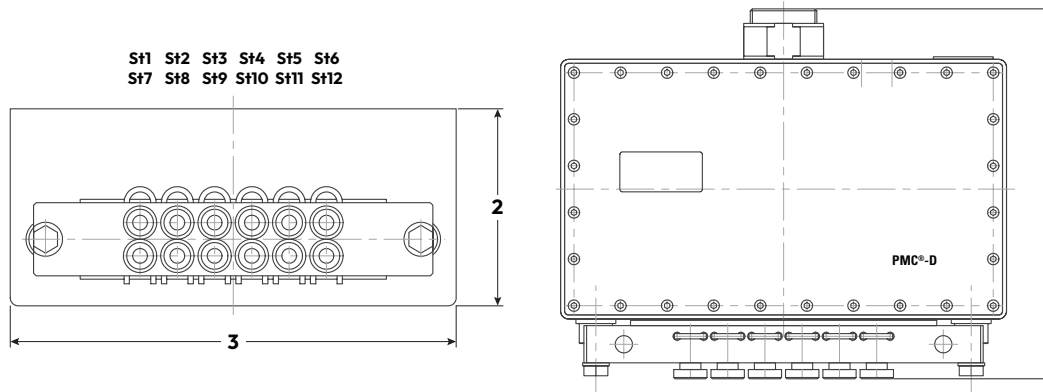

1	Width	278 mm	10.94 in
2	Height	148 mm	5.83 in
3	Length	335 mm	13.19 in

PMC-D20 Dimensions and Plug Assignments

All dimensions are approximate.

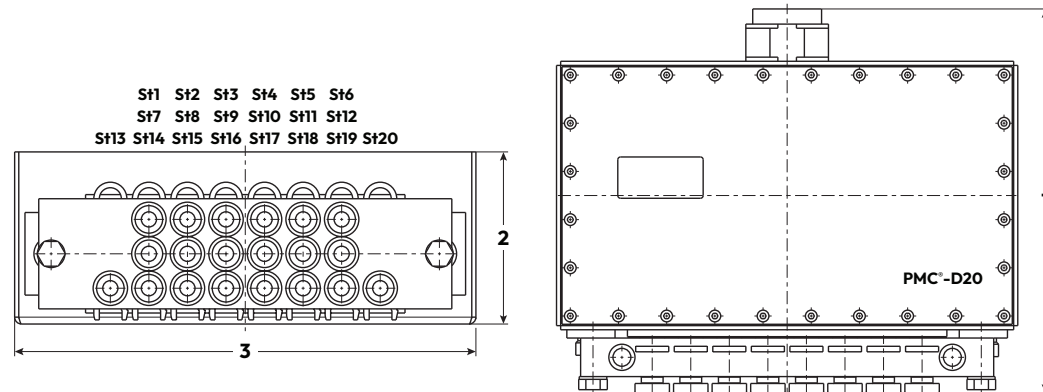

1	Width	279 mm	10.98 in
2	Height	125 mm	4.92 in
3	Length	335 mm	13.19 in

PMC-D/PMC-D20 Drive Control Unit

Electrical Sockets

Socket	Pin 1	Pin 2	Pin 3	Pin 4
St1	Optocoupler Anode	Relay Contact NO: a	Relay Contact NO: b	Optocoupler Cathode
St2	+12 V (A) (output)	Serial Interface: RxD_O	Serial Interface: TxD_O	GND
St3	+12 V (B) (output)	Serial Interface: RxD_B	Serial Interface: TxD_B	GND
St4	+12 V (C) (output)	Serial Interface: RxD_C	Serial Interface: TxD_C	GND
St5	+12 V (C) (output)	Switch 1	Switch 2	GND
St6		Profibus: a (internal)	Profibus: b (internal)	
St7	+12 V (Power Supply)			GND (Power Supply)
St8	Multi Mode Input 4	Multi Mode Input 1	+8.2 V (output)	GND
St9	Multi Mode Input 5	Multi Mode Input 2	+8.2 V (output)	GND
St10	+12 V (output)	Multi Mode Input 3	+8.2 V (output)	GND
St11	+12 V (output)	Multi Mode Input 6	+8.2 V (output)	GND
St12		TP a	TP b	
St13		CM-Sensor +	CM-Sensor -	CM-GND
St14		CM-Sensor +	CM-Sensor -	CM-GND
St15		CM-Sensor +	CM-Sensor -	CM-GND
St16		CM-Sensor +	CM-Sensor -	CM-GND
St17		CM-Sensor +	CM-Sensor -	CM-GND
St18		CM-Sensor +	CM-Sensor -	CM-GND
St19		CM-Sensor +	CM-Sensor -	CM-GND
St20		CM-Sensor +	CM-Sensor -	CM-GND